

# Audible/Visual Alarm

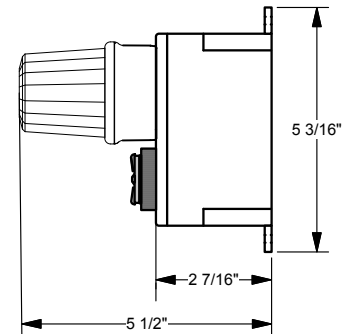
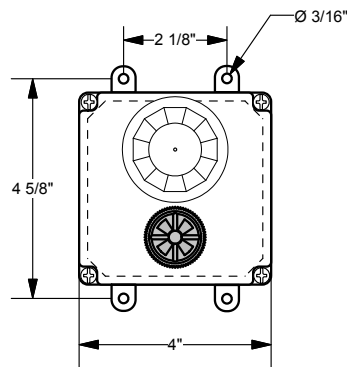

## AVPWMSN120C

### Kit includes:

- UL Type 4X 4"x4"x2" box with external mounting feet
- Holes cut out for Ingram's PW120A and MSN120A
- PW120A- UL Type 4X, 120 VAC piezo warbler \*\*
- MSN120A - UL Type 4X, 120 VAC strobe light \*  
Includes all necessary hardware except mounting hardware for box.

## AVPWSBN120C

### Kit includes:

- UL Type 4X 4"x4"x2" box with external mounting feet
- Holes cut out for Ingram's PW120A and SBN120A
- PW120A- UL Type 4X, 120 VAC piezo warbler \*\*
- SBN120A - UL Type 4x, 120 VAC LED light \*
- Includes all necessary hardware except mounting hardware for box.

## AVPWSBN1224C

### Kit includes:

- UL Type 4X 4"x4"x2" box with external mounting feet
- Pre-cut holes for mounting the components.  
PW12D or PW24D - UL Type 4X, 12 or 24 VDC
- piezo warbler \*\*
- SBN1224AD - UL Type 4x, 12/24V AC/DC LED
- light \*
- Includes all necessary hardware except mounting hardware for box.

\*Lens available in red, blue, green, amber, or clear. Please specify color at time of order. If no color is specified red is standard.

\*\* Piezo warbler available in red or black.